

GLOBAL JOURNAL OF ENGINEERING SCIENCE AND RESEARCHES
IDENTIFICATION AND CLASSIFICATION OF POWER QUALITY DISTURBANCES
BY AN EFFECTIVE WAVELET BASED NEURAL CLASSIFIER

Prof. A. P. Padol

Department of Electrical Engineering, MGICOET Shegaon

ABSTRACT

This paper presents a wavelet based neural for identification and classification of Power Quality disturbances. The disturbances to be classified from the power system under study and it is simulated in Power System Computer Aided Design (PSCAD). In this paper, the Power Quality disturbances to be identified and classified with the help of Discrete Wavelet Transform and Artificial Neural Network. Power Quality disturbances will be detected by using Discrete Wavelet Transform (DWT) and classified by using Artificial Neural Network (ANN). Discrete Wavelet Transform is used to extract the disturbance features in the power signal. Power quality disturbances are localized by Discrete Wavelet Transform in time and frequency domain. Multi-Resolution Analysis (MRA) technique of Discrete Wavelet Transform is used to decompose the power signal at 7-level which gives detailed and approximate coefficients. These detailed coefficients of DWT are used to calculate Statistical parameters given as input to ANN to classify Power quality disturbances.

Keywords: *Power System Computer Aided Design, Discrete Wavelet Transform, Artificial Neural Network, Multi-Resolution Analysis.*

I. INTRODUCTION

A. The main of the power system is to provide reliable and uninterrupted services to its customers at a rated voltage and frequency within a constrained variation limit. In order to maintain the uninterrupted power supply, all the power quality constraints should be followed by both power utilities and End users. The electrical system should not be able to provide cheap, safe and secure energy to the consumers but also to compensate for the continuously changing load demand. During that process, the quality of power could be distorted by fault on the system or by the switching. The demand for Electrical Energy is increasing rapidly as a result of huge investment made to generate power and transmit it over a long distance. In recent years, Power Quality has become an important issue to both power utilities and their customer. Most of the power system disturbances are non stationary and transitory in nature. Due to the use of Non-linear load, solid state switching devices and other power electronics equipments cause power disturbances which result in poor power quality. This poor power quality results in the failure of the End user equipments. Thus detection and classification of Power Quality disturbances is a challenging task for Power System engineers. So, in order to improve the Power Quality, Power Quality disturbances should be detected, localised and classified accurately so that appropriate action can be taken to mitigate it.

B. Related Work

Mario Oleskovics et al [1] presents a Distribution system to study the disturbance affecting Power Quality. In this paper, DWT technique to detect and locate the disturbance in a power signal. The energy of each disturbance is calculated and given as input to ANN for classification.

Masoud Karimi et al [2] present a new method of on-line voltage disturbance detection based on Wavelet transform which depends on simulation of large number of faults and Capacitor switching incident. In this, a probability function is defined and decision is made using Maximum Likelihood criteria which is based on maximizing the probability function of the features.

Z. L. Gaing et al [3] proposed a Wavelet based Neural network classifier to detect and classify the power quality disturbance. Using Multi Resolution Analysis technique of DWT, 13-level decomposition of each disturbance signal is performed. Parseval theorem is used to calculate the energy which is given as input to ANN for classification.

P. K. Dashanand et al [4] proposed a new technique consisting of Fourier linear combiner and a Fuzzy expert system for classification of power quality disturbance. Using peak amplitude and computed slope obtained from Fourier linear combiner are given to Fuzzy expert diagnostic module to compute the truth value of signal. Then the disturbances are classified as Sag, Swell and Interruption using defined Fuzzy set.

S. Mishra et al [5] presents a s- transform based Neural network classifier to detect and classify the power quality disturbance. In this paper, s- transform is used to detect the disturbance in a power signal and classified using PNN which shows that s- transform has better detection capability and Probabilistic Neural Network (PNN) gives best classification results.

C. Objective of work:

The main objective of this paper is detection and classification following Power Quality disturbances such as (i) Voltage Sag (ii) Voltage Swell (iii) Interruption. Power quality disturbances are detected using Discrete Wavelet Transform and classified using Artificial Neural Network.

II. WAVELET TRANSFORM:

A wave is an oscillating function of time or space and is periodic. In contrast, wavelets are localized waves. They have their energy concentrated in time or space and are suited to analysis of transient signals. While Fourier Transform and Short Time Fourier Transform (STFT) use waves to analyze signals, the Wavelet Transform uses wavelets of finite energy.

The wavelet analysis is done similar to the STFT analysis. The signal to be analyzed is multiplied with a wavelet function just as it is multiplied with a window function in STFT, and then the transform is computed for each segment generated. However, unlike STFT, in Wavelet Transform, the width of the wavelet function changes with each spectral component. The Wavelet Transform, at high frequencies, gives good time resolution and poor frequency resolution, while at low frequencies; the Wavelet Transform gives good frequency resolution and poor time resolution.

There are different wavelets such as Haar, Daubechies 4, Symlet and Coiflet which are used as mother wavelet.

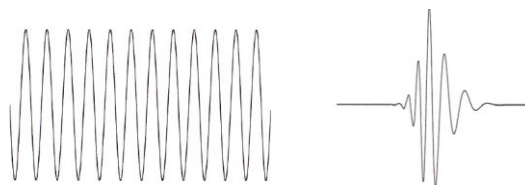

Fig. 1 Wavelet representation

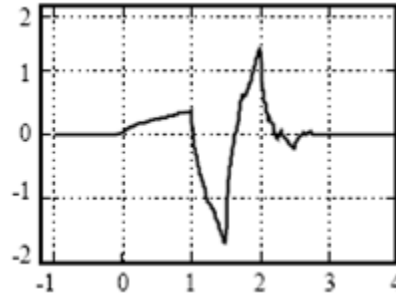

Fig. 2 Daubechies 4 Wavelet

III. DISCRETE WAVELET TRANSFORM (DWT):

DWT is any wavelet transform in which the wavelet is discretely sampled. DWT transforms the distorted signal into different time frequency scales which detect disturbances present in the power signal.

The DWT of $f(t)$ is defined as:

$$\text{DWT } f(a,b) = \sum f(t) \psi_{a,b}(t) \quad (1)$$

Where $\psi_{a,b}$ is the mother wavelet

a, b are scale and translation factor

A. Multi Resolution Analysis (MRA):

The first main characteristic of Wavelet transform is Multi resolution analysis. The signal is analysis at different frequencies with different resolution in Multi resolution analysis technique. This technique decomposes the given signal into several other signals with different levels of resolution and provides valuable information in time and frequency domain. Fig.I shows seven level decomposition of DWT which uses the wavelet function (ψ) and scaling function (ϕ) It decompose the signal into high frequency components and low frequency components by processing the signal through high and low pass filters. The wavelet function ψ generate – detailed coefficient (high frequency component) and scaling function ϕ generate – approximated coefficient (low frequency component).

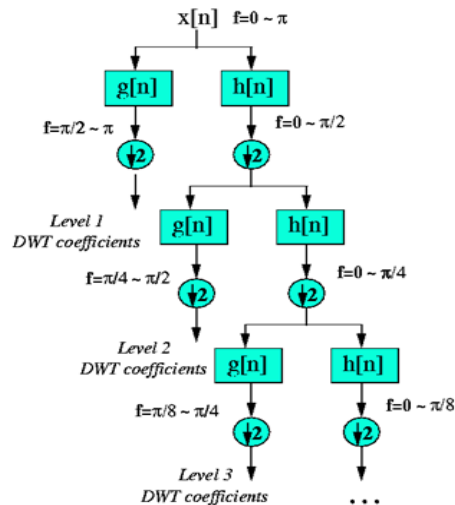

Fig. 2 Seven-level decomposition using MRA technique

Table I. Level of Decomposition

Levels	Approximations –cAi	Detail-cDi
Frequency Band width		
1 ⁰	0 – 1920	1920 – 3840
2 ⁰	0 – 960	960 – 1920
3 ⁰	0 – 480	480 – 960
4 ⁰	0 – 240	240 – 480
5 ⁰	0 – 120	120 – 240
6 ⁰	0 – 60	60 – 120
7 ⁰	0 – 30	30 – 60

B. Feature extractor:

Feature extraction is a pre-processing operation that transforms a pattern from its original form to a new form suitable for further processing. Mapping the data of the distorted signal into a wavelet domain is the first step in performing the feature extraction process. The power signal with disturbance when subjected to DWT will generate a discontinuous state at the start and end points of the disturbance duration. For each of the disturbance, the DWT coefficients generated have variations which are used to recognize the various power signal disturbance and thereby classifying the different power quality problems. By applying DWT, the distorted signal can be mapped into the wavelet domain and represented by a set of wavelet coefficients.

C. Statistical parameter as Feature Extractor:

A statistical parameter is a parameter that indexes a family of probability distributions. It can be regarded as a numerical characteristic of a population or a model. Statistic is a quantity that is calculated from a sample of data. It is used to give information about unknown values in the corresponding population.

In this Method, Statistical parameter is used as Feature Extractor. DWT extract the disturbance features in power signal. DWT localizes the Power Quality disturbances in time and frequency. In this method of classification also, Daubechies “db4” wavelet is used and decomposition is carried upto 7 – level. After 7 – level decomposition, we get detailed and approximate coefficient. Six statistical parameter such as Minimum, Maximum, Energy, Standard deviation, Skewness, Kurtosis are calculated from detailed coefficients. These six statistical parameters are given as input to ANN for classification.

Various statistical parameter are

- (1) Minimum (2) Maximum (3) Mean (4) Median
- (5) Sum (6) Absolute sum (7) RMS value (8)Energy
- (9)Kurtosis (10) Crest factor (11)Shape factor
- (12)Standard deviation (13) Variance (14)Skewness

IV. CASE STUDY

Fig.II. shows a single line diagram IEEE 14-Bus system. The system under study for detection and classification of Power Quality disturbances is simulated in PSCAD software. It consists of 5-Generators, 3-Transformers, 11-load buses and a shunt capacitors. The detail configuration of IEEE 14-Bus system is given in Appendix. Fig shows PSCAD simulation diagram of IEEE 14-Bus system.

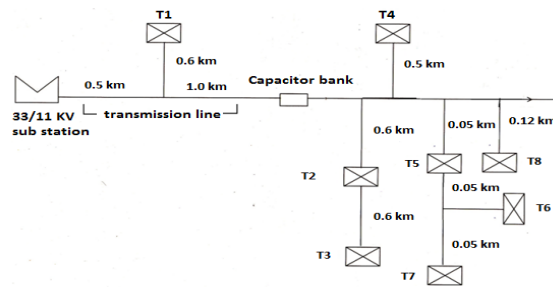

. Fig. 3 Single line diagram of Distribution system

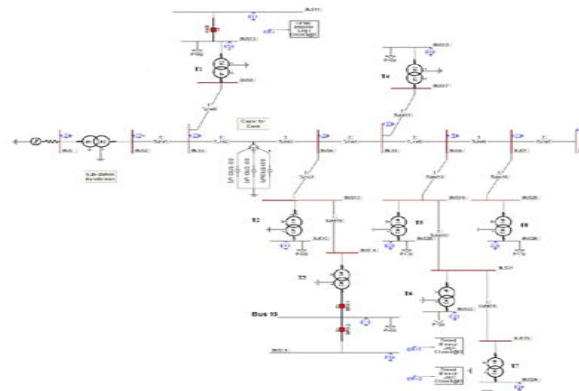

Fig.4 PSCAD Simulation of Distribution system

V. PROPOSED METHODOLOGY

A given Distribution system is simulated in PSCAD software. Power Quality disturbances such as Voltage Sag, Voltage swell and Interruption are generated in the system at different inception angles. The Voltage signal are captured at different Buses and sampled at 7680 Hz. This sampled voltage signals saves in excel sheets and given to MATLAB program for DWT analysis. For DWT analysis, Daubechies ‘db4’ wavelet is used for feature extraction and decomposition is carried upto 7-level. Statistical parameter are calculated from detailed coefficients after 7-level decomposition, given as input to ANN to classify Voltage Sag, Voltage swell and Interruption.

VI. FLOWCHART

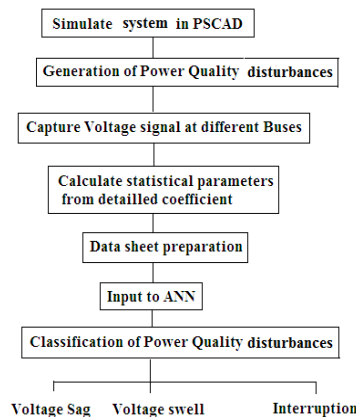

Fig. 5 Flowchart of Proposed Methodology

VII. PSCAD SIMULATION WAVEFORMS:

(i) Voltage Sag : The voltage waveform when a LG fault occurs is as shown below.

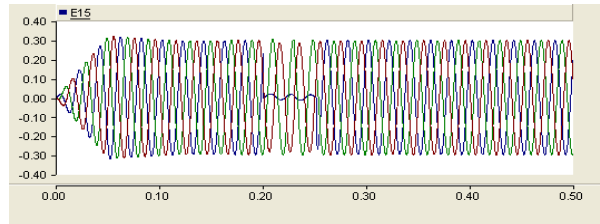

Fig. 6 Voltage waveform for Voltage sag

(ii) Voltage swell: The voltage waveform when a heavy load is switch-off is as shown below.

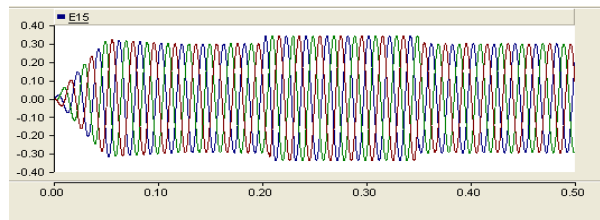

Fig.7 Voltage waveforms for Voltage swell

(iii) Interruption: The voltage waveform when a inadvertent operation of a Circuit breaker take place is shown below.

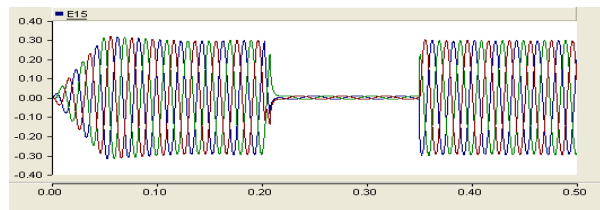

Fig.8 Voltage waveform for Interruption

VIII. DWT WAVEFORMS FOR 7-LEVEL DECOMPOSITION

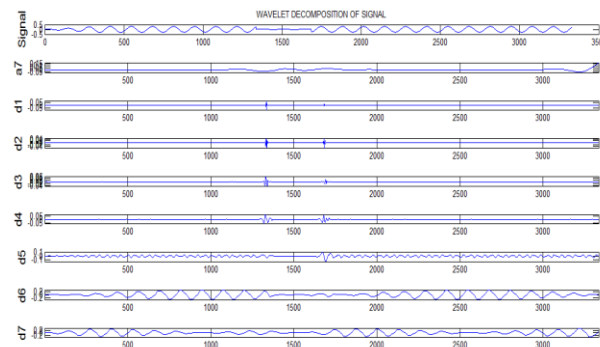

Fig.9 DWT waveform for Voltage sag

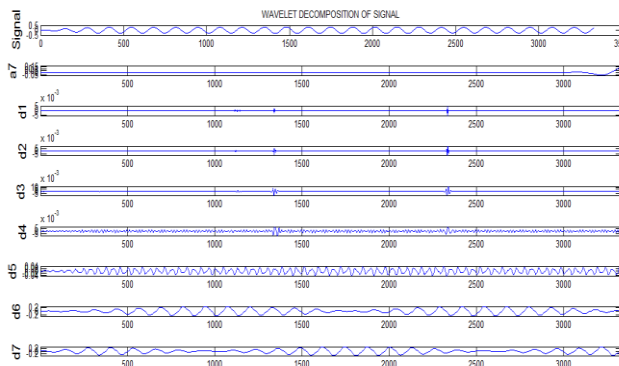

Fig.10 DWT waveform for Voltage swell

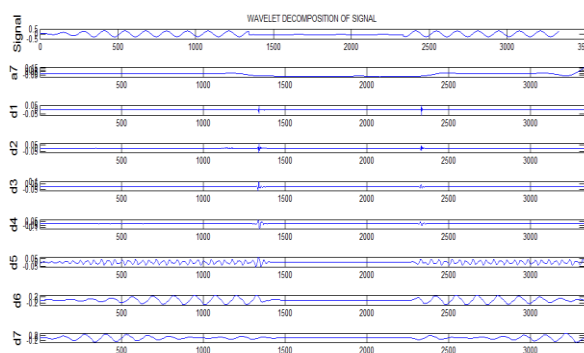

Fig.11 DWT waveform for Interruption

IX. ARTIFICIAL NEURAL NETWORK (ANN) AS A CLASSIFIER

ANN is defined as a computing system made up of a number of simple, highly interconnected processing elements, which process information by their dynamic state response to external inputs. An artificial neural network is a system based on the operation of biological neural networks, in other words, is an emulation of biological neural system. Neural networks are typically organized in layers. Layers are made of a number of interconnected ‘nodes’ which contain ‘activation function’. Patterns are presented to the the network via the ‘input layer’, which communicates to one or more ‘hidden layers’ where the actual processing is done via a system of weighted ‘connection’. The hidden layers then link to an ‘output layer’ where the answer is output as shown in the Fig. below.

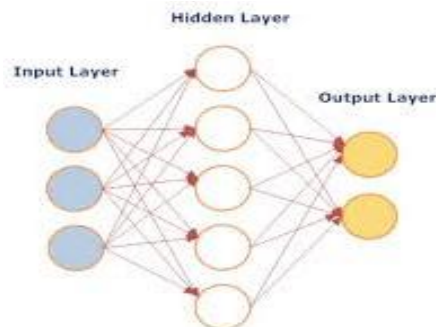

Fig.12 Artificial Neural Network (ANN)

A. ANN Network details:

The learning Rule: Momentum

Testing data: 25 %

Momentum : 7.00000

Network used: Multi layer Perceptron (MLP)

Hidden layer : 3

Training data : 75 %

Step size: 1.00000

Transfer: TanhAxon

B. ANN Output :

For 4-processing elements and 3- hidden layers, ANN gives the following output.

Table II. ANN Output:

Performance	Sag	Swell	Interruption
MSE	0.000527	0.000963	0.0010195
NMSE	0.002482	0.003924	0.005453
MAE	0.020743	0.029663	0.027672
Min Abs Error	0.007261	0.018864	0.000345
Max Abs Error	0.039423	0.052961	0.0464087
r	0.999880	0.999833	0.999889
Percent Correct	100	100	100

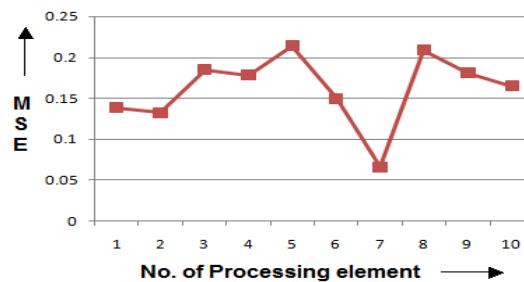

Fig.13 Variations of MSE with Number of Processing element

X. CONCLUSION

This paper presents an effective wavelet-based neural classifier method to identify and classify types of power quality disturbances. The disturbances to be classified from the distribution system are voltage sag, voltage swell, and interruption. These power quality disturbances are detected and classified accurately so that appropriate action can be taken to mitigate them, which improves the performance of the system. ANN, which is used as a classifier, gives 100% accuracy for classification.

REFERENCES

1. Mário Oleskovicz *, Denis V. Coury, Odilon Delmont Felho, Wesley F. Usida, Adriano A.F.M. Carneiro, Leandro R.S. Pires, "Power quality analysis applying a hybrid methodology with wavelet transforms and neural networks", *Electric Power and Energy System* 2009, 206–212.
2. Masoud Karimi, Hossein Mokhtari, and M. Reza Iravani, "Wavelet Based On-Line Disturbance Detection for Power Quality Applications", *IEEE Trans. Power Delivery*, vol.15, no. 4, October 2000.
3. Z. L. Gaing, "Wavelet-based neural network for power disturbance recognition and classification", *IEEE Trans. Power Delivery*, vol. 19, pp. 1560–1567, Oct. 2004.
4. P. K. Dashand, M. M. A. Salama, and S. Mishra, "Classification of power system disturbances using a fuzzy expert system and a Fourier linear combiner," *IEEE Trans. Power Delivery*, vol. 15, pp. 472–477, Apr. 2000.

[NC-Rase 18]

DOI: 10.5281/zenodo.1489825

ISSN 2348 – 8034

Impact Factor- 5.070

5. S. Mishra, C. N. Bhende, and B. K. Panigrahi, Senior Member, IEEE, “ Detection and Classification of Power Quality Disturbances Using S-Transform and Probabilistic Neural Network ,” *IEEE Trans. Power Delivery*, vol. 23, pp. 280–287, Jan. 2008.
6. S. Santosa, E.J. Powers, W.M. Grady, A.C. Parsons: *Power Quality Disturbance Waveform Recognition using Wavelet-based Neural Classifier*, *IEEE Power Engineering Society Winter Meeting*, 1997.
7. M. Brent Hughes, John S. Chan, and Don O. Koval, “ Distribution Customer Power Quality Experience,” *IEEE Trans. on Industry Applications*, Vol. 29, No. 6, November/December 1993, pp. 1204-1211.
8. A.K. Ghosh, D.L. Lubkeman: *The Classification of Power System Disturbance Waveforms using a Neural Network Approach: IEEE Trans. on Power Delivery*, Vol. 10, No. 7, 1990, pp. 671-683.
9. E.W. Gunther and H. Mehta: *A Survey of Distribution System Power Quality- Preliminary Results*, *IEEE Trans. Power Delivery*, Vol. 10, pp. 322-329, Jan. 1995.